

## Laboratory sinks

### Laboratory sink

#### Intended use

- Water supply and disposal
- For cleaning operating equipment
- To take up large amounts of water
- Not suitable for the disposal of chemicals

#### Design

- 1 Underbench unit  
2 Sink  
3 Outlet

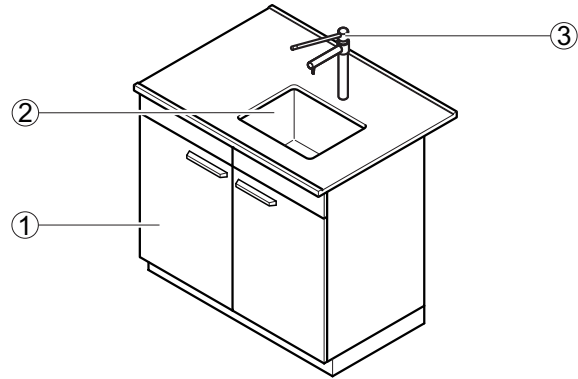

#### Technical data

Material Worktop	Material Sinks	Sink dimensions Width x depth x height [mm]	Type of installation
Stoneware	Stoneware	400 x 400 x 250 500 x 400 x 250	Sink installed flush with the worktop
Melamine resin facing, Solid grade laminate, Trespa Toplab+	Polypropylene	320 x 320 x 200 400 x 400 x 250 500 x 400 x 250	Sink with surrounding increased edge installed in the worktop from above
Melamine resin facing, Solid grade laminate, Trespa Toplab+	Stainless steel	340 x 370 x 150 500 x 400 x 250	Sink with surrounding increased edge installed in the worktop from above
Polypropylene	Polypropylene	385 x 385 x 250 485 x 385 x 250	Sink attached to the worktop from the bottom and welded
Stainless steel	Stainless steel	400 x 400 x 250 500 x 400 x 250	Sink welded in flush with the worktop
Composite worktop	Stoneware	380 x 380 x 250 530 x 380 x 250	Sink installed flush with the worktop
Epoxy	Epoxy	406 x 305 x 203 406 x 406 x 190 457 x 380 x 279	Sink installed flush with the worktop

Dimensions					
Width [mm]	600	900	1200	1500	1800
Depth [mm]			600 <sup>1)</sup> 675 <sup>1)</sup> 705 <sup>1)</sup> 750 825 855 900		
Working height [mm]			900		

<sup>1)</sup> Positioning of the outlets on the side of the sink, if required

Sanitary technology	
Water connection	Permanent connection
Waste water connection	Permanent connection with siphon
Water fitting (tap)	Bench-mounted service outlet as an option
Eye shower	Optional

## Laboratory sinks

### Laboratory sink module

#### Intended use

- Water supply and disposal
- For cleaning operating equipment
- To take up large amounts of water
- For installation on special underbench units
- Not suitable for the disposal of chemicals

#### Design

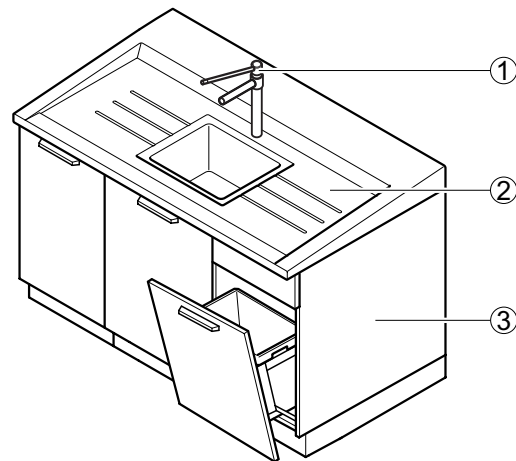

- 1 Outlet  
2 Sink module  
3 Underbench unit (3-piece)

#### Variants

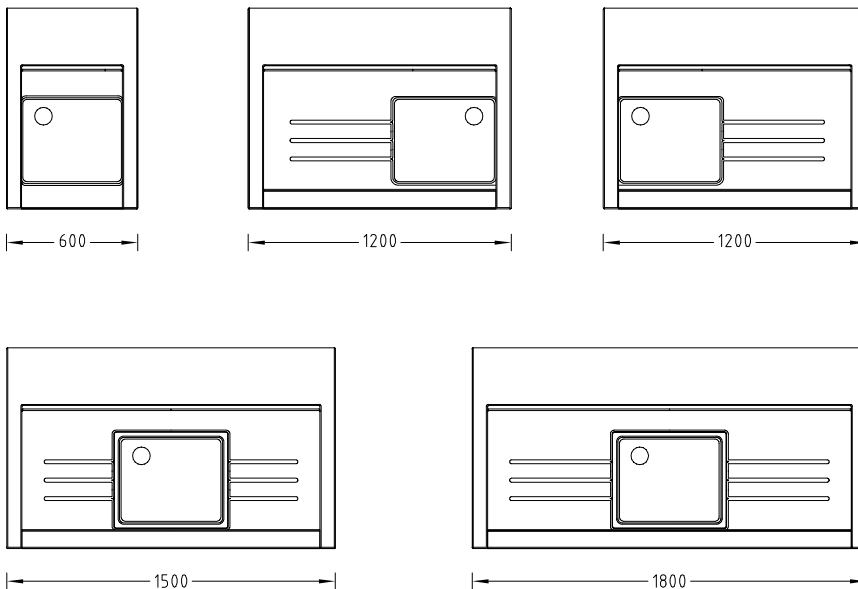

# Laboratory sinks

## Laboratory sink module

### Technical data

Dimensions				
Width, sink module [mm]	600	1200	1500	1800
Depth, sink module for wall bench with service spine [mm]	675 or 825			
Depth, sink module for double bench with service spine [mm]	705 or 855			
Depth, sink module in front of building wall [mm]	760 or 910			
Depth, sink module as an end sink [mm]	-		740	
Overall height, sink module with underbench unit [mm]	910 front to 950 rear			
Sink dimensions, width x depth x height [mm]	460 x 390 x 250			
Height, edge of sink [mm]	20 front to 50 rear			

### Material

Sink module	Stoneware
-------------	-----------

### Design characteristics

Construction	Self-supporting moulded draining area Surrounding increased edge
Modular design	Different underbench units possible As end sink with special underbench unit

### Sanitary technology

Water connection	Permanent connection
Waste water connection	Permanent connection with siphon
Water fitting (tap)	Bench-mounted service outlets as an option
Eye shower	Optional

## Laboratory sinks

### Drip cup on service spine

#### Intended use

- Water supply and disposal
- For cleaning operating equipment
- Sink module underneath water fittings to take up small amounts of water
- Not suitable for the disposal of chemicals

#### Design

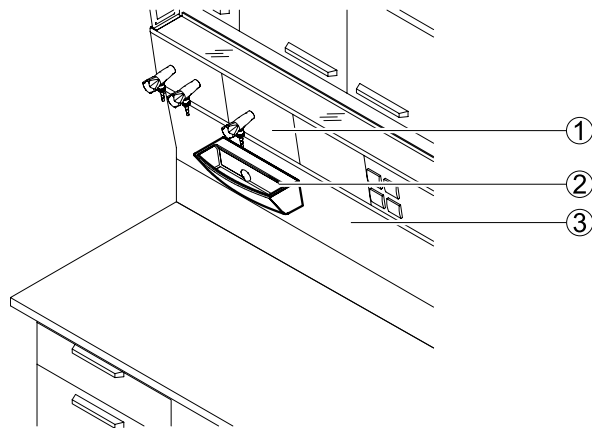

- 1 Service panel with corner valves
- 2 Sink module
- 3 Fascia panel for service spine

#### Technical data

Dimensions	
Width [mm]	294
Depth [mm]	132
Height [mm]	112
Internal sink dimensions width x depth x height [mm]	Approx. 270 x 85 x 80

Material	
Sink module	Stoneware Polypropylene

Design characteristics	
Construction	Attached to the fascia panel of the service spine

Sanitary technology	
Water connection	Permanent connection
Waste water connection	Permanent connection with siphon
Water fitting (tap)	Cell outlets as an option

## Laboratory sinks

### Drip cup in worktop

#### Intended use

- Water supply and disposal
- For cleaning operating equipment
- Drip cup underneath water fittings to take up small amounts of water
- Not suitable for the disposal of chemicals

#### Design

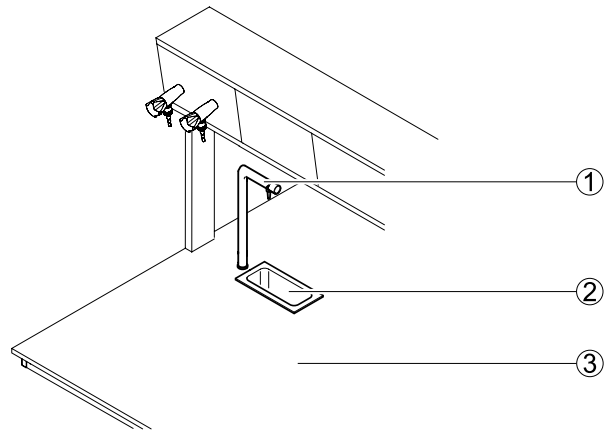

- 1 Outlet  
2 Drip cup  
3 Worktop

#### Technical data

Dimensions	
Width x depth [mm]	295 x 145
Height [mm]	Approx. 125 to 140 depending on material
Internal sink dimensions width x depth x height [mm]	Approx. 250 x 100 x 150

Material, drip cup	Material, worktop
Stoneware	Stoneware, composite worktop
Polypropylene	Polypropylene, melamine resin facing, solid grade laminate, Trespa Toplab+
Stainless steel	Stainless steel, melamine resin facing, solid grade laminate, Trespa Toplab+
Epoxy	Epoxy

Design characteristics	
Construction	Installed in the worktop from the top or bottom

Sanitary technology	
Water connection	Permanent connection
Waste water connection	Permanent connection with siphon
Water fitting (tap)	Bench-mounted service outlets as an option

## Laboratory sinks

### Mobile sink

#### Intended use

- Mobile water and gas supply and disposal
- For cleaning operating equipment at any location
- Not suitable for the disposal of chemicals

#### Design

- 1 Connecting pipes
- 2 Fitting with two cold water outlet points
- 3 Worktop
- 4 Sink
- 5 Underbench unit on castors

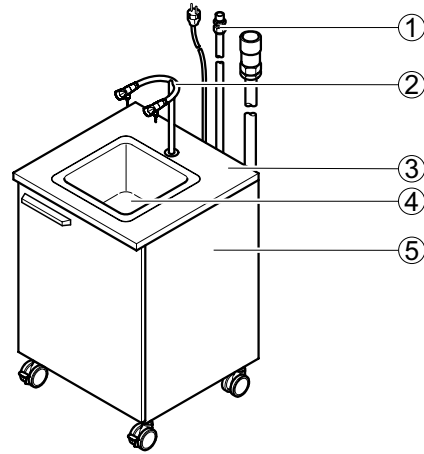

#### Technical data

Dimensions	
Width [mm]	605
Depth [mm]	600
Height without outlet [mm]	900
Sink dimensions width x depth x height [mm]	320 x 320 x 200
Height, [mm] castors	110
Length, supply and drain pipes [mm]	2500
Length, connecting pipes [mm]	2500

Material	
Worktop	Particle-board with melamine resin facing
Sink	Polypropylene

Load bearing capacity	
Mobile sink [kg]	150

Design characteristics	
Construction	Mounted on underbench unit on castors with hinged door Sink installed in the worktop from above Pipes and cables routed out at the rear of the underbench unit Waste water lifting unit in the underbench unit Water supply is switched off in the case of a power failure

Electrics	
Power supply [V]	230

Sanitary technology	
Water connection	Flexible with plug connector
Waste water connection	Flexible with plug connector
Gas connection	Flexible with plug connector as an option
Water fitting (tap)	Standard outlet
Gas outlet	Standard outlet combined with water fitting as an option
Mixer tap	Additional flexible water connection as an option

## Laboratory sinks

### AquaEL

#### Intended use

- Mobile water and gas supply and disposal
- For cleaning operating equipment at the workplace at any mobile or stationary laboratory workstation
- Not suitable for the disposal of chemicals

#### Design

- 1 Connecting pipes
- 2 Outlet with water outlet point
- 3 Housing with pump
- 4 Sink

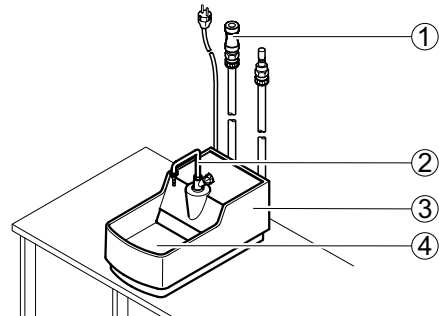

#### Technical data

Dimensions	
Width x depth x height (without outlet) [mm]	317 x 585 x 268
Sink, width x depth x height [mm]	260 x 275 x 105
Length, supply and drain pipes [mm]	1500
Length, connecting pipes [mm]	1500

Weight	
Weight without outlet [kg]	14

Material	
Material	GFK varnished

Design characteristics	
Construction	Compact system with flexible pipes and cables ready for connection Waste water lifting unit integrated in the housing Water supply is switched off in the case of a power failure

Electrics	
Power supply [V]	230

Sanitary technology	
Water connection	Flexible with plug connector
Waste water connection	Flexible with plug connector
Gas connection	Flexible with plug connector as an option
Water fitting (tap)	Standard outlet
Gas outlet	Standard outlet combined with water fitting as an option
Mixer tap	Additional flexible water connection as an option