

Suspended service boom

Intended use

- Services supply from the ceiling for:
 - ▶ Laboratory benches below the suspended service boom
 - ▶ Laboratory equipment on mobile tables or underbench constructions
 - ▶ Floor-mounted laboratory equipment
- Design versions for genetical engineering areas
- Modular fastening of boom add-on parts to the supporting construction, e.g. glass shelves and OSB board, scaffold points, etc.
- Tool-free installation of supplementary service duct add-on parts such as monitor arm, pipette holder, paper towel dispenser, universal storage area, etc.

Design

- 1 Service panel with sockets
- 2 Service panel with corner valves
- 3 Shelf of OSB board
- 4 Media supply duct
- 5 Ceiling stator
- 6 Functional element
- 7 Glass shelf
- 8 Pillar
- 9 Storage area (service duct)
- 10 Service duct element

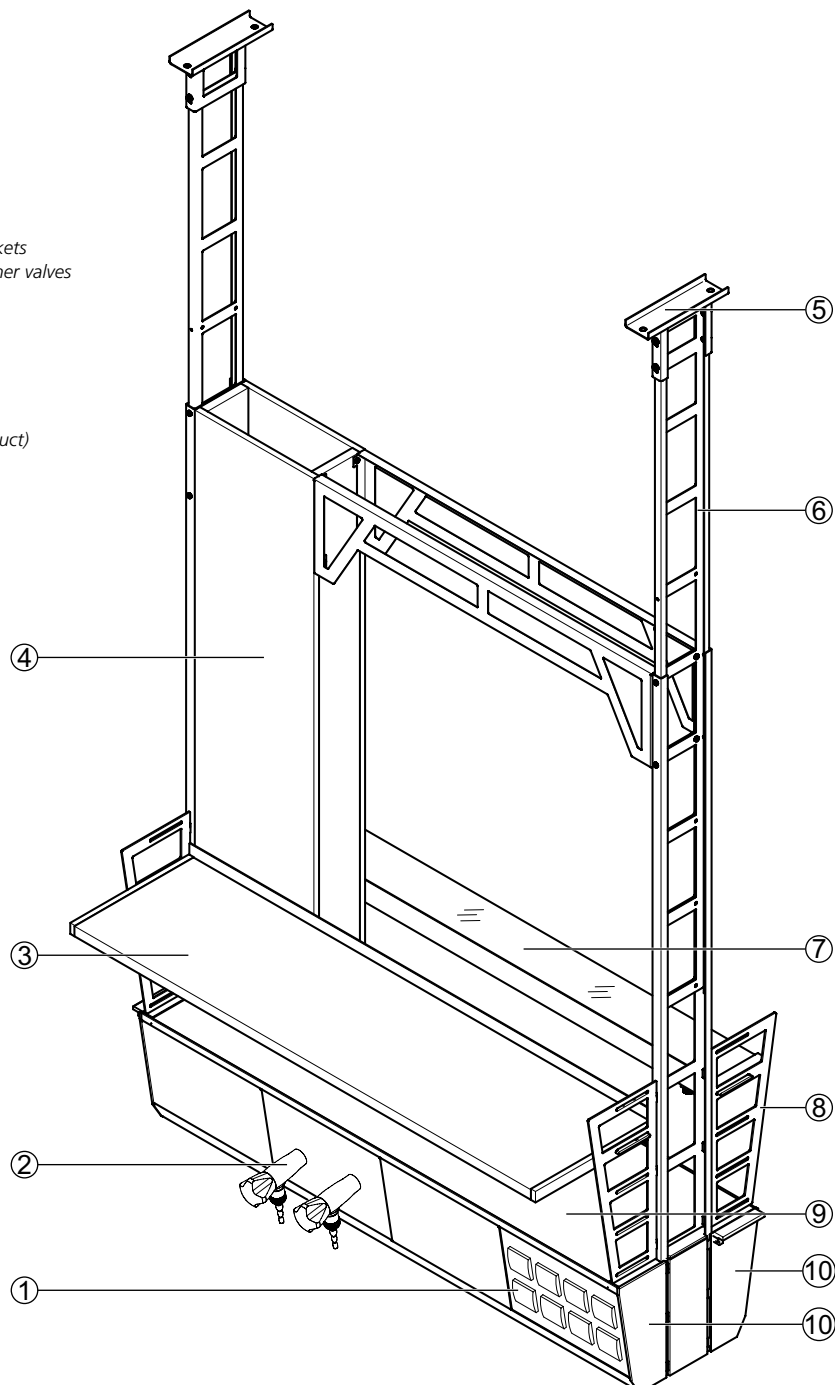

Suspended service boom

Technical data

Dimensions					
Width [mm]	600	900	1200	1500	1800
Depth [mm] without pillars	350				
Depth [mm] with pillars	471				
Recommended min. height [mm] bottom edge of suspended service boom to upper edge of finished floor	1750				
Height, supporting construction (max. up to ceiling height 4000 mm)	Depending on ceiling height				
Service panel, width x height [mm]	300 x 200				
Glass shelf, width x depth [mm]	Width, suspended service boom x 150				
Shelf of OSB board, width x depth [mm]	Width, suspended service boom x 300				

Load bearing capacity	
Maximum permissible load [kg]	120
Additional max. load bearing capacity, suspended service boom [kg] per grid	30
Glass shelf [kg]	20
Shelf of OSB board [kg]	30
Scaffold points [kg]	5

Design characteristics	
Construction	Functional elements to take up service ducts fastened to the ceiling and connected
Number of service panels (per side)	Depending on the width of the service duct
Scaffold points \varnothing [mm]	12 to 13

Material	
Storage area (service duct)	Solid grade laminate 5 mm

Electrics	
Electrical supply	Sockets in the service panel
Fuse box	Optional

Sanitary technology	
Sanitary supply	Service panel with take-off valves for vacuum, gases and/or waters Supply pipes and cables in supply duct from above