

Bench-mounted service duct

Intended use

- Services supply of double work benches
- Design versions for genetical engineering areas
- Modular fastening of cell add-on parts to the multipurpose uprights, e.g. glass shelves and OSB board, overbench cabinets, scaffold points, etc.
- Tool-free installation of supplementary service duct add-on parts such as pegboard, monitor arm, pipette holder, paper towel dispenser, universal storage area, etc.
- Not suitable for double benches where separate work surfaces are required (see also BGI/GUV-I 850-0)

Design

Bench-mounted service duct with cantilever frame and suspended underbench unit

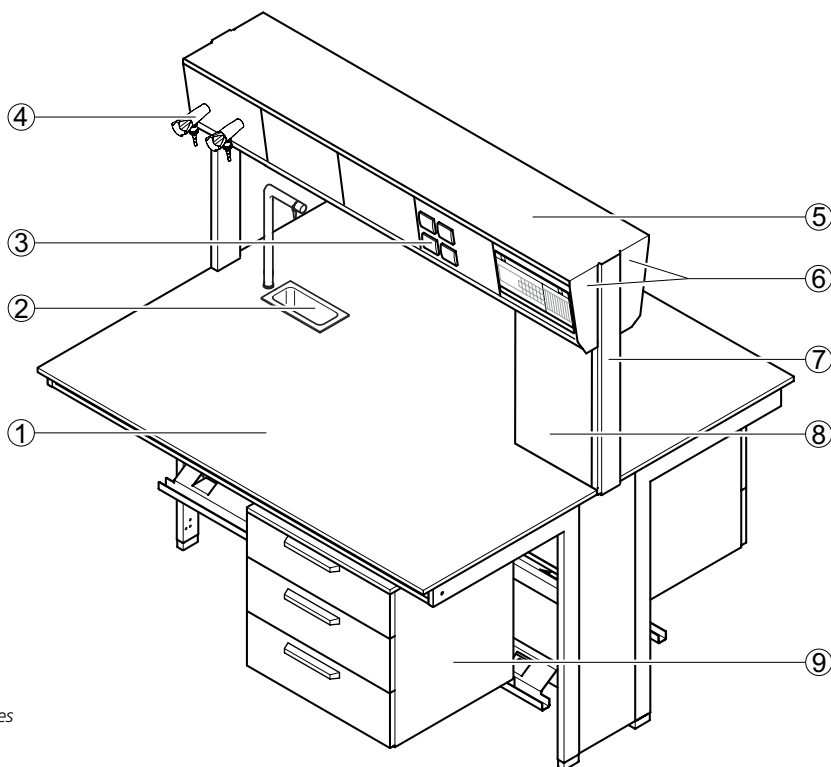

- 1 Worktop
- 2 Drip cup with water outlet
- 3 Service panel with sockets
- 4 Service panel with corner valves
- 5 Storage area, service duct
- 6 Service duct element
- 7 Multipurpose upright
- 8 Media supply duct
- 9 Suspended underbench unit

Bench-mounted service duct

Bench-mounted service duct with overbench cabinets, H-frame and underbench units on castors

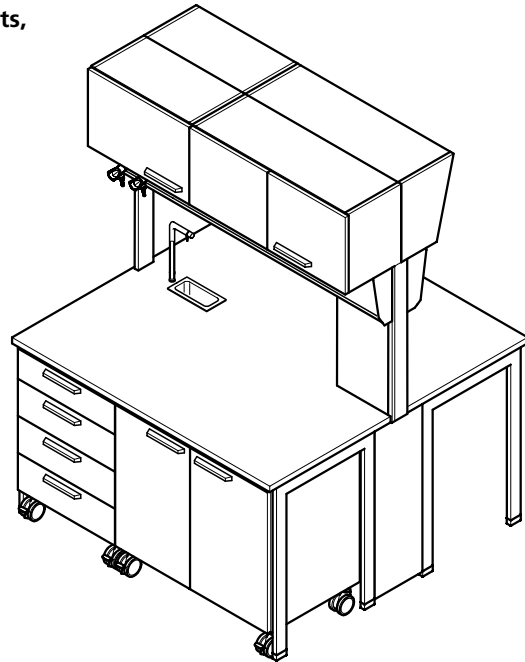

Bench-mounted service duct with overbench cabinets, pillar extension and underbench units on plinth

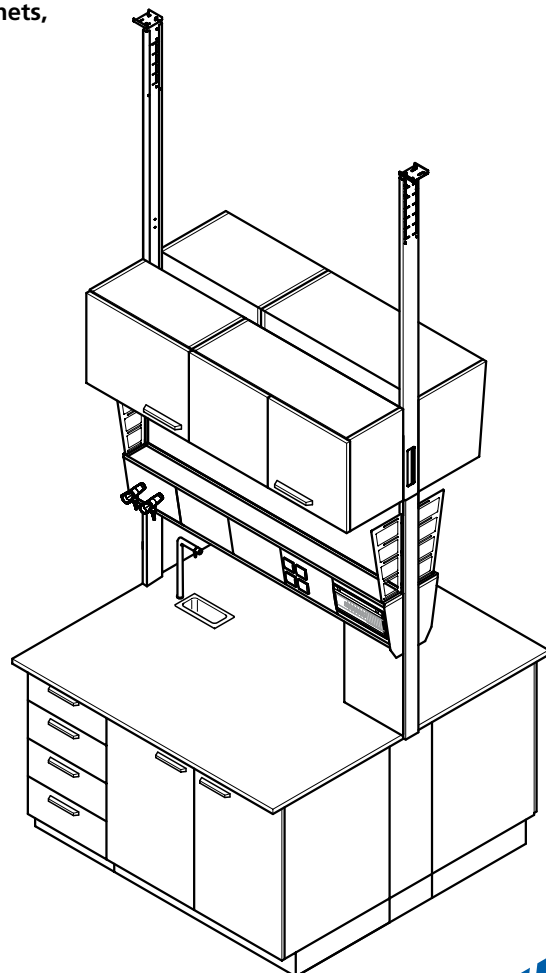

Bench-mounted service duct

Technical data

Dimensions					
Width [mm]	600	900	1200	1500	1800
Depth [mm]	310				
Height [mm]	1602				
Height, opening at working height 900 mm [mm]	450				
Height, pillar extension [mm] (for overbench cabinet, height 460 mm)	462				
Height, pillar extension [mm] (for overbench cabinet, height 760 mm)	762				
Height, pillar extension [mm] (up to ceiling height 3500 mm)	Depending on ceiling height				
Service panel, width x height [mm]	300 x 200				
Glass shelf, width x depth [mm]	Width, bench-mounted unit x 150				
Shelf of OSB board, width x depth [mm]	Width, bench-mounted unit x 300				

Load bearing capacity	
Glass shelf [kg]	20
Shelf of OSB board [kg]	30
Scaffold points [kg]	5

Design characteristics	
Construction	Double-sided service duct as bench-mounted unit with opening above the worktop
Number of service panels	Depending on duct width
Scaffold points ø [mm]	12 to 13

Material	
Storage area, service duct	Solid grade laminate shelf 5 mm

Electrics	
Electrical supply	Sockets in the service panel
Fuse box	Optional

Sanitary technology	
Sanitary supply	Service panel with take-off valves for vacuum, gases and/or waters Supply pipes in the bench-mounted unit