

Bench-mounted fume cupboards with side installation

Bench-mounted fume cupboard with side installation

Intended use

- Protective device for the user, tested in acc. with EN 14175
- Extraction of fumes, aerosols and dust from the internal workspace to prevent dangerous amounts of pollutants from escaping into the laboratory
- To prevent the formation of dangerous potentially explosive atmospheres in the internal workspace
- Protection from splashes of hazardous substances
- Protection from flying particles, bodies or parts escaping from the internal workspace
- General fume cupboards constructed in acc. with EN 14175 are normally not suited for use with radioactive substances or microorganisms
- Not suitable for openly breaking down chemicals
- Service outlets in the service modules of the side panels of the internal workspace
- Control units located vertically on the side service panels

Design

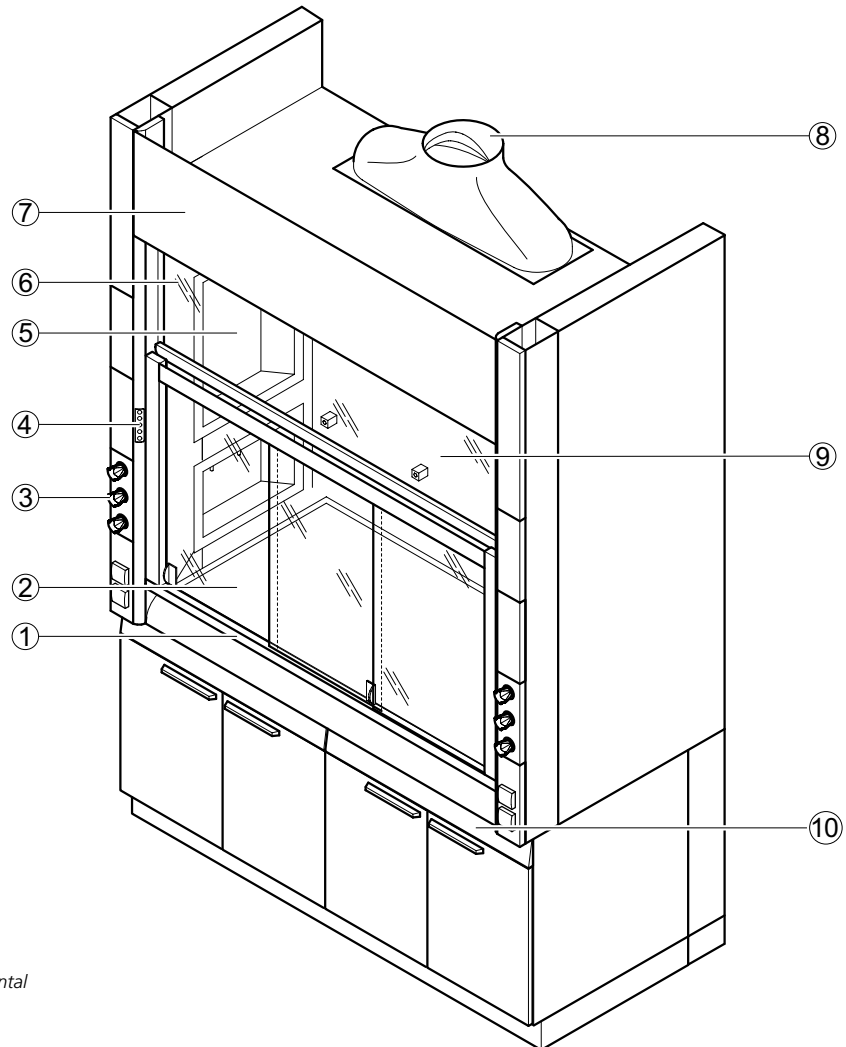

- 1 Sash with handle and horizontal sashes
- 2 Worktop
- 3 Service panel
- 4 FAZ or AC control panel
- 5 Service modules in the side panel of the fume cupboard
- 6 Upper sash window
- 7 Removable fascia panel
- 8 Extract manifold
- 9 Baffle with scaffold points
- 10 Self-supporting underbench unit

Bench-mounted fume cupboards with side installation

Bench-mounted fume cupboard with side installation

Dimensional drawing

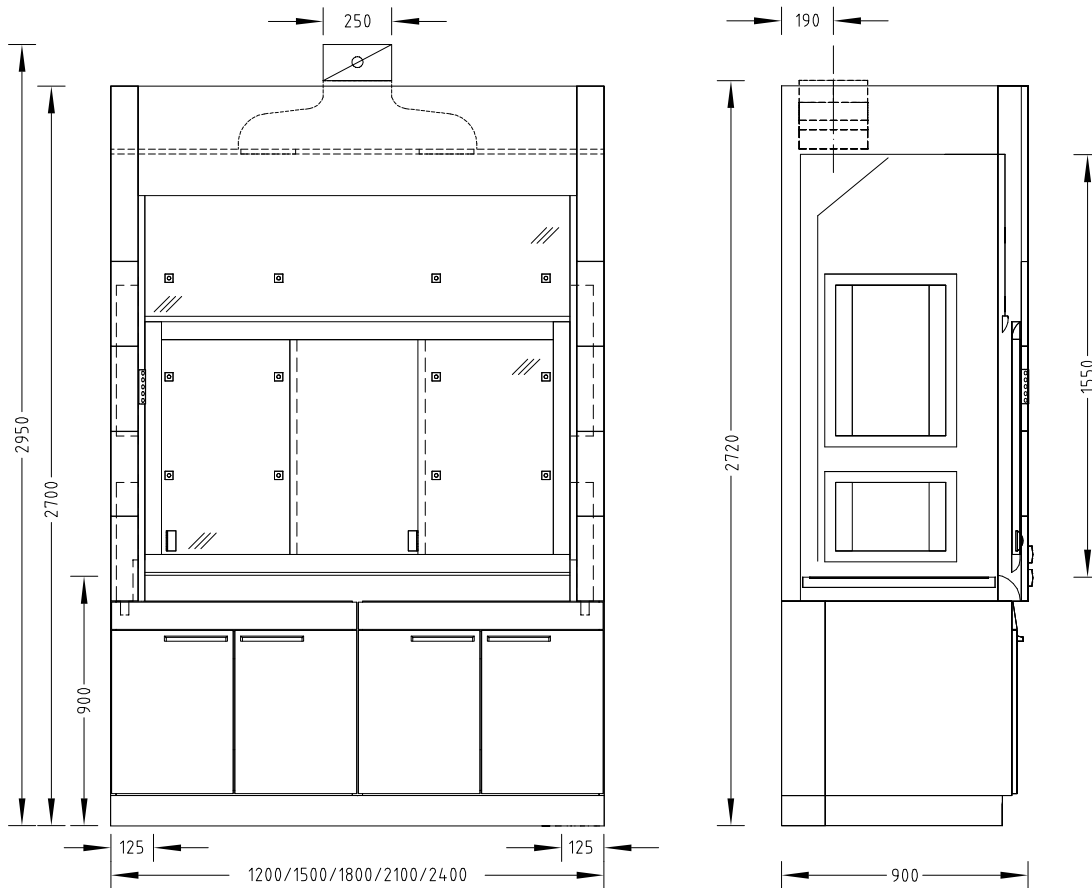

Technical data

Dimensions	1200	1500	1800	2100	2400
Width [mm]	1200	1500	1800	2100	2400
Depth [mm]	900				
Height [mm]	2700				
Clear width, internal workspace [mm]	950	1250	1550	1850	2150
Clear height, internal workspace [mm]	1550				
Working height [mm]	900				

Weight	1200	1500	1800	2100	2400
Without installation [kg]	Approx. 320	Approx. 390	Approx. 450	Approx. 510	Approx. 570

Bench-mounted fume cupboards with side installation

Bench-mounted fume cupboard with side installation

Design characteristics	1200	1500	1800	2100	2400
Supporting construction	Self-supporting underbench units or H-frame with push-in underbench units				
Sash	2 horizontal sashes		3 horizontal sashes		
Side panel of the fume cupboard	Glass pane on the left and/or right as an option; not if service modules are installed in the side panel of the fume cupboard Material lock on the left and/or right as an option				
Max. number of devices for scaffold points, ø 12 to 13 mm	9	12		15	
Service modules	Service modules in the left and/or right side panel of the fume cupboard, depending on requirement				

Electrics	
Electrical supply	External sockets in service panels Internal sockets in service modules
Fuse box	Optional
Sash controller SC	Optional

Sanitary technology	
Sanitary supply	Service modules with take-off valves for vacuum, gases and/or waters and integrated sink (PP) as an option

Ventilation technology	1200	1500	1800	2100	2400
Minimum air exchange rate [m ³ /h] ¹⁾	420	530	630	740	840
Function display	FAZ				
Airflow damper, constant	Airflow-Controller AC				
Airflow damper, variable	Airflow-Controller AC				
Detector of sash position	Only variable with Airflow-Controller AC				
Connection height [mm] for FAZ with extract manifold Ø 250 mm	2720				
Connection height [mm] for FAZ with extract manifold Ø 315 mm ²⁾	2830				
Connection height [mm] for AC with extract manifold Ø 250 mm	2950				
Connection height [mm] for AC with extract manifold Ø 315 mm ²⁾	3070				
Underbench exhaust	As an option, depending on requirements and regulations				

¹⁾ All air volume specifications refer to an opening height of the sash window of 500 mm (test opening in acc. with EN 14175) and the maximum tracer gas values recommended by German Standard (BG Chemie). Shown rates correspond to a face velocity of 0.24 m/s. For other design face velocities, please contact your Waldner sales representative.

²⁾ In order to minimise noise and pressure losses, for air volumes >1000 m³/h Waldner recommends using the extract manifold with a connection diameter of 315 mm.

A maximum admission pressure of 600 Pa should not be exceeded in the case of fume cupboards with airflow dampers. The indicated minimum air exchange rates were determined under specified test conditions in acc. with EN 14175-3. These minimum air exchange rates must be adapted when dimensioning the ventilation system.

If on-site extract air monitoring systems or airflow dampers are used, the required air volumes may be different. The operating limitations must be agreed upon with Waldner.

Material/surface	
Worktop	Stoneware (not for bench-mounted fume cupboard with a width of 2400 mm) Polypropylene Epoxy Stainless steel
Internal lining	Solid grade laminate Stainless steel Melamine resin facing

Bench-mounted fume cupboards with side installation

Low ceiling bench-mounted fume cupboard with side installation

Intended use

- Protective device for the user, tested in acc. with EN 14175
- Extraction of fumes, aerosols and dust from the internal workspace to prevent dangerous amounts of pollutants from escaping into the laboratory
- To prevent the formation of dangerous potentially explosive atmospheres in the internal workspace
- Protection from splashes of hazardous substances
- Protection from flying particles, bodies or parts escaping from the internal workspace
- General fume cupboards constructed in acc. with EN 14175 are normally not suited for use with radioactive substances or microorganisms
- Not suitable for openly breaking down chemicals
- Service outlets in the service modules of the side panels of the internal workspace
- Control units located vertically on the side service panels
- Suitable for rooms with low ceiling height

Design

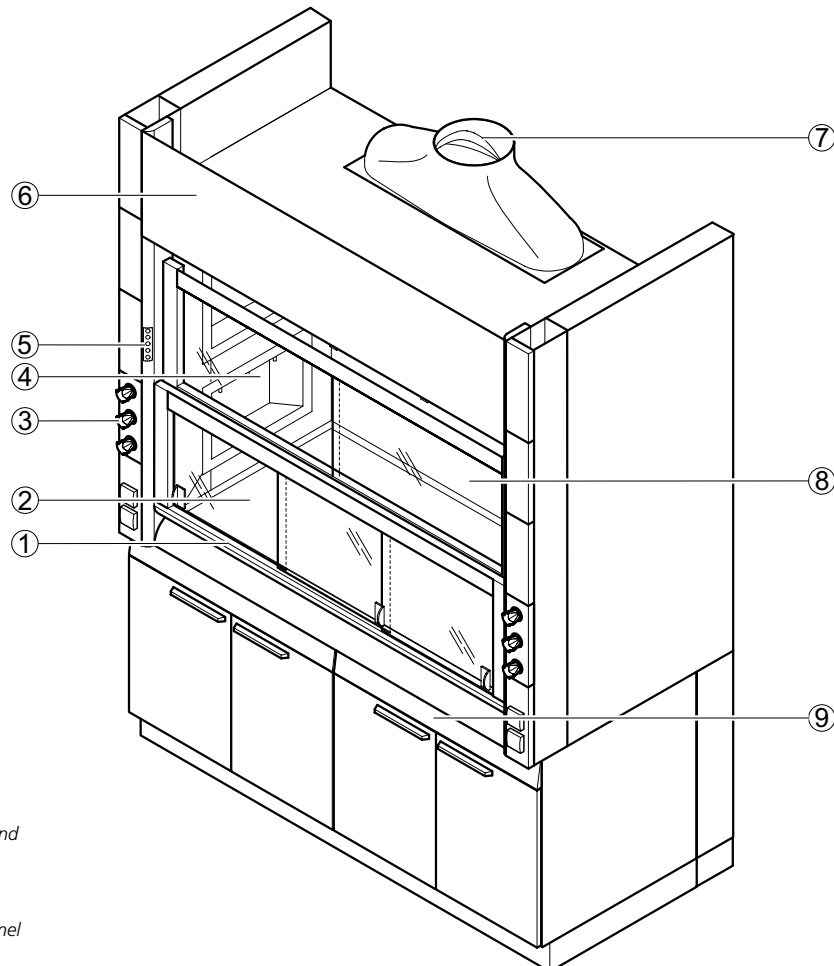

- 1 Two-piece sash with handle and horizontal sashes
- 2 Worktop
- 3 Service panel
- 4 Service module in the side panel of the fume cupboard
- 5 FAZ or AC control panel
- 6 Removable fascia panel
- 7 Extract manifold
- 8 Baffle with scaffold points
- 9 Self-supporting underbench unit

Bench-mounted fume cupboards with side installation

Low ceiling bench-mounted fume cupboards with side installation

Dimensional drawing

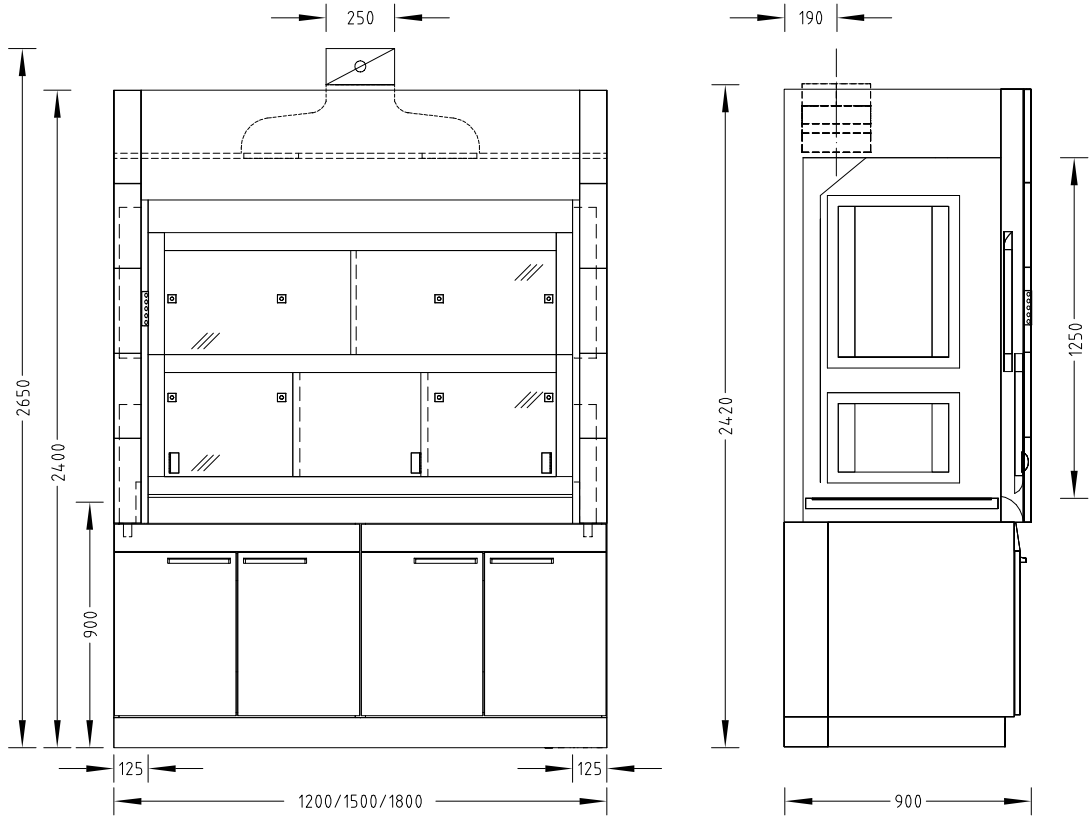

Technical data

Dimensions	1200	1500	1800
Width [mm]	1200	1500	1800
Depth [mm]	900		
Height [mm]	2400		
Clear width, internal workspace [mm]	950	1250	1550
Clear height, internal workspace [mm]	1250		
Working height [mm]	900		

Weight	1200	1500	1800
Without installation [kg]	Approx. 220	Approx. 260	Approx. 300

Design characteristics	1200	1500	1800
Supporting construction	Self-supporting underbench units or H-frame with push-in underbench units		
Two-piece sash	2 horizontal sashes		3 horizontal sashes
Side panel of the fume cupboard	Glass pane on the left and/or right as an option; not if service modules are installed in the side panel of the fume cupboard, not with stoneware internal lining Material lock on the left and/or right as an option		
Max. number of devices for scaffold points, ø 12 to 13 mm	6	8	
Service modules	Service modules in the left and/or right side panel of the fume cupboard, depending on requirement		

Bench-mounted fume cupboards with side installation

Low ceiling bench-mounted fume cupboard with side installation

Electrics	
Electrical supply	External sockets in service panels Internal sockets in service modules
Fuse box	Optional
Sash controller SC	Optional

Sanitary technology	
Sanitary supply	Service modules with take-off valves for vacuum, gases and/or waters and integrated sink (PP) as an option

Ventilation technology	1200	1500	1800
Minimum air exchange rate [m ³ /h] ¹⁾	420	530	630
Function display	FAZ		
Airflow damper, constant	Airflow-Controller AC		
Airflow damper, variable	Airflow-Controller AC		
Detector of sash position	Only variable with Airflow-Controller AC		
Connection height [mm] for FAZ with extract manifold Ø 250 mm	2420		
Connection height [mm] for FAZ with extract manifold Ø 315 mm ²⁾	2530		
Connection height [mm] for AC with extract manifold Ø 250 mm	2650		
Connection height [mm] for AC with extract manifold Ø 315 mm ²⁾	2770		
Underbench exhaust	As an option, depending on requirements and regulations		

¹⁾ All air volume specifications refer to an opening height of the sash window of 500 mm (test opening in acc. with EN 14175) and the maximum tracer gas values recommended by German Standard (BG Chemie). Shown rates correspond to a face velocity of 0.24 m/s. For other design face velocities, please contact your Waldner sales representative.

²⁾ In order to minimise noise and pressure losses, for air volumes >1000 m³/h Waldner recommends using the extract manifold with a connection diameter of 315 mm.

A maximum admission pressure of 600 Pa should not be exceeded in the case of fume cupboards with airflow dampers.

The indicated minimum air exchange rates were determined under specified test conditions in acc. with EN 14175-3. These minimum air exchange rates must be adapted when dimensioning the ventilation system.

If on-site extract air monitoring systems or airflow dampers are used, the required air volumes may be different. The operating limitations must be agreed upon with Waldner.

Material/surface	
Worktop	Stoneware Polypropylene Epoxy Stainless steel
Internal lining	Solid grade laminate Stainless steel Melamine resin facing

Bench-mounted fume cupboards with side installation

Secuflow bench-mounted fume cupboard with side installation

Intended use

- Protective device for the user, tested in acc. with EN 14175
- Extraction of fumes, aerosols and dust from the internal workspace to prevent dangerous amounts of pollutants from escaping into the laboratory
- To prevent the formation of dangerous potentially explosive atmospheres in the internal workspace
- Protection from splashes of hazardous substances
- Protection from flying particles, bodies or parts escaping from the internal workspace
- General fume cupboards constructed in acc. with EN 14175 are normally not suited for use with radioactive substances or microorganisms
- Not suitable for openly breaking down chemicals
- Active supportive flow technology (Secuflow technology) reduces the energy consumption while regulations and standards are observed
- Service outlets in the service modules of the side panels of the internal workspace
- Control units located vertically on the side service panels

Design

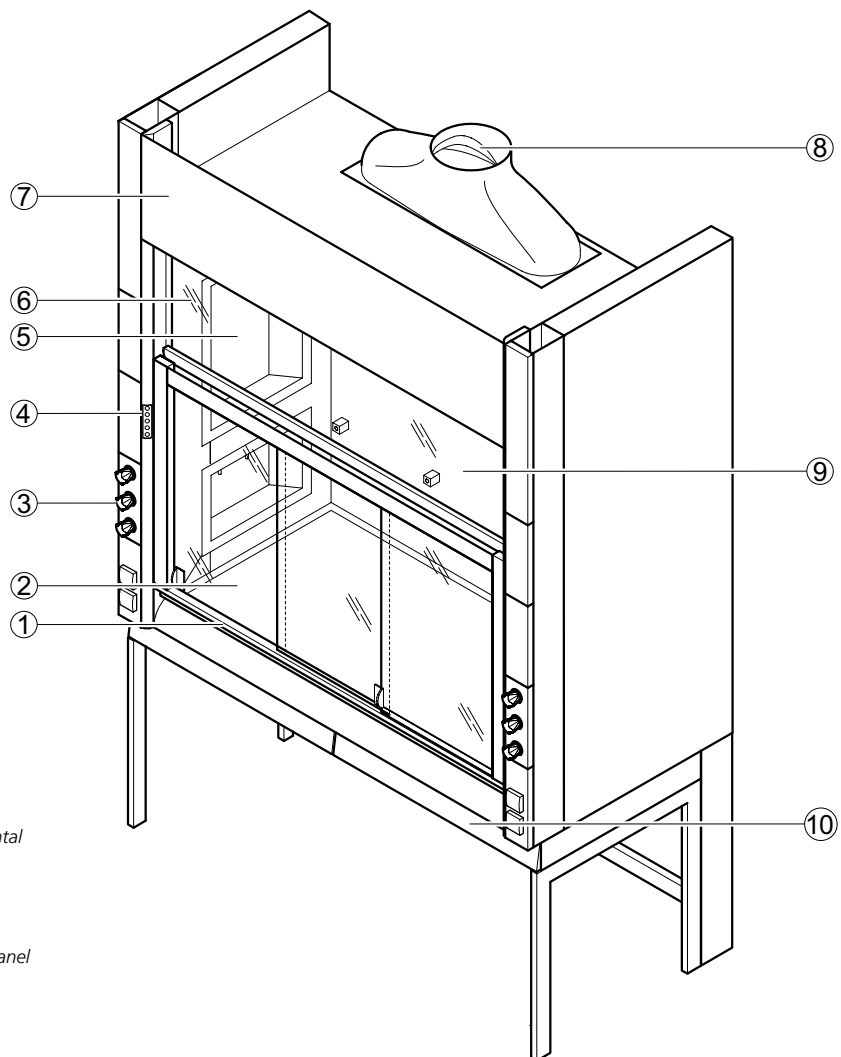

- 1 Sash with handle and horizontal sashes
- 2 Worktop
- 3 Service panel
- 4 FAZ or AC control panel
- 5 Service modules in the side panel of the fume cupboard
- 6 Upper sash window
- 7 Removable fascia panel
- 8 Extract manifold
- 9 Baffle with scaffold points
- 10 Support frame with push-in underbench units as an option

Bench-mounted fume cupboards with side installation

Secuflow bench-mounted fume cupboard with side installation

Dimensional drawing

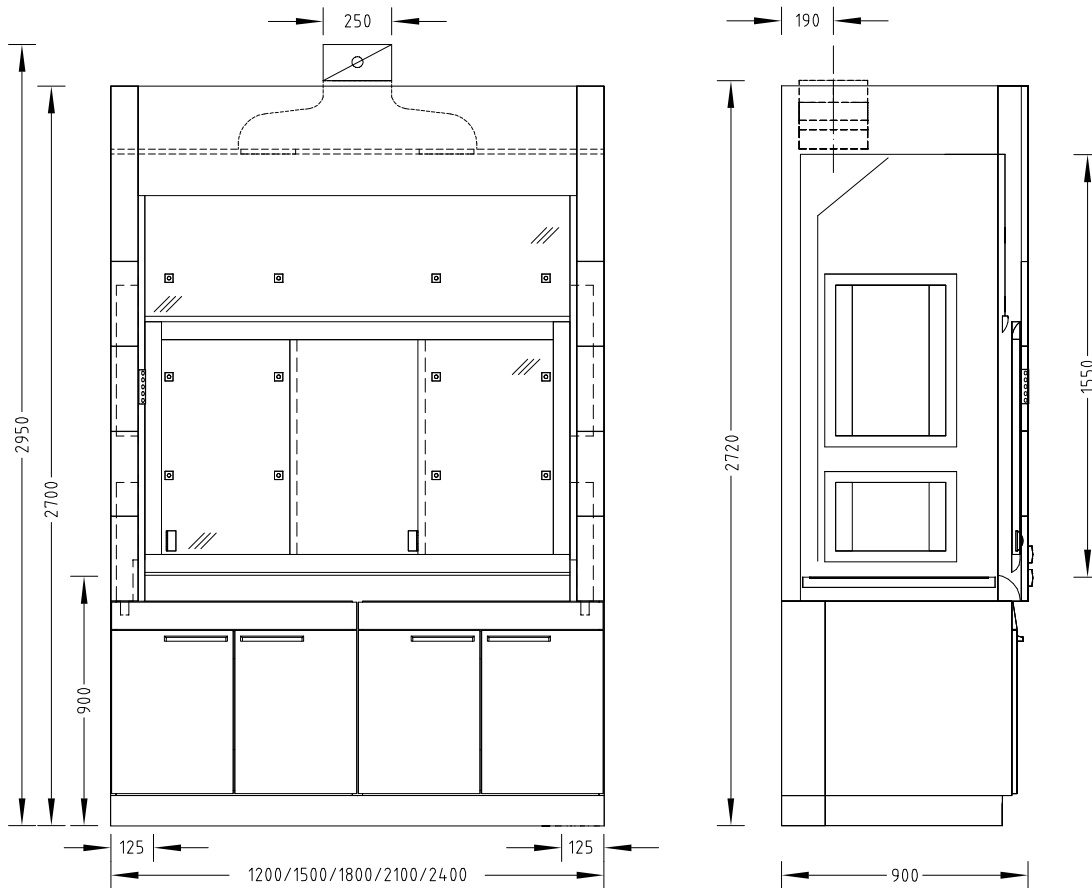

Technical data

Dimensions	1200	1500	1800	2100	2400
Width [mm]	1200	1500	1800	2100	2400
Depth [mm]	900				
Height [mm]	2700				
Clear width, internal workspace [mm]	950	1250	1550	1850	2150
Clear height, internal workspace [mm]	1550				
Working height [mm]	900				

Weight	1200	1500	1800	2100	2400
Without installation [kg]	Approx. 320	Approx. 390	Approx. 450	Approx. 510	Approx. 570

Bench-mounted fume cupboards with side installation

Secuflow bench-mounted fume cupboard with side installation

Design characteristics	1200	1500	1800	2100	2400
Supporting construction	Self-supporting underbench units or H-frame with push-in underbench units				
Sash	2 horizontal sashes		3 horizontal sashes		
Side panel of the fume cupboard	Glass pane on the left and/or right as an option; not if service modules are installed in the side panel of the fume cupboard Material lock on the left and/or right as an option				
Max. number of devices for scaffold points, ø 12 to 13 mm	9	12		15	
Service modules	Service modules in the left and/or right side panel of the fume cupboard, depending on requirement				

Electrics	
Electrical supply	External sockets in service panels Internal sockets in service modules
Fuse box	Optional
Sash controller SC	Optional

Sanitary technology	
Sanitary supply	Service modules with take-off valves for vacuum, gases and/or waters and integrated sink (PP) as an option

Ventilation technology	1200	1500	1800	2100	2400
Minimum air exchange rate [m ³ /h] ¹⁾	330	410	490	570	650
Function display	FAZ				
Airflow damper, constant	Airflow-Controller AC				
Airflow damper, variable	Airflow-Controller AC				
Detector of sash position	Only variable with Airflow-Controller AC				
Connection height [mm] for FAZ with extract manifold Ø 250 mm	2720				
Connection height [mm] for FAZ with extract manifold Ø 315 mm ²⁾	2830				
Connection height [mm] for AC with extract manifold Ø 250 mm	2950				
Connection height [mm] for AC with extract manifold Ø 315 mm ²⁾	3070				
Underbench exhaust	As an option, depending on requirements and regulations				

¹⁾ All air volume specifications refer to an opening height of the sash window of 500 mm (test opening in acc. with EN 14175) and the maximum tracer gas values recommended by German Standard (BG Chemie). Shown rates correspond to a face velocity of 0.15 m/s. For other design face velocities, please contact your Waldner sales representative.

²⁾ In order to minimise noise and pressure losses, for air volumes >1000 m³/h Waldner recommends using the extract manifold with a connection diameter of 315 mm.

A maximum admission pressure of 600 Pa should not be exceeded in the case of fume cupboards with airflow dampers. The indicated minimum air exchange rates were determined under specified test conditions in acc. with EN 14175-3. These minimum air exchange rates must be adapted when dimensioning the ventilation system.

If on-site extract air monitoring systems or airflow dampers are used, the required air volumes may be different. The operating limitations must be agreed upon with Waldner.

Material/surface	
Worktop	Stoneware (not for bench-mounted fume cupboard with a width of 2400 mm) Polypropylene Epoxy Stainless steel
Internal lining	Solid grade laminate Stainless steel Melamine resin facing

Bench-mounted fume cupboards with side installation

Secuflow low ceiling bench-mounted fume cupboard with side installation

Intended use

- Protective device for the user, tested in acc. with EN 14175
- Extraction of fumes, aerosols and dust from the internal workspace to prevent dangerous amounts of pollutants from escaping into the laboratory
- To prevent the formation of dangerous potentially explosive atmospheres in the internal workspace
- Protection from splashes of hazardous substances
- Protection from flying particles, bodies or parts escaping from the internal workspace
- General fume cupboards constructed in acc. with EN 14175 are normally not suited for use with radioactive substances or microorganisms
- Not suitable for openly breaking down chemicals
- Active supportive flow technology (Secuflow technology) reduces the energy consumption while regulations and standards are observed
- Service outlets in the service modules of the side panels of the internal workspace
- Control units located vertically on the side service panels
- Suitable for rooms with low ceiling height

Design

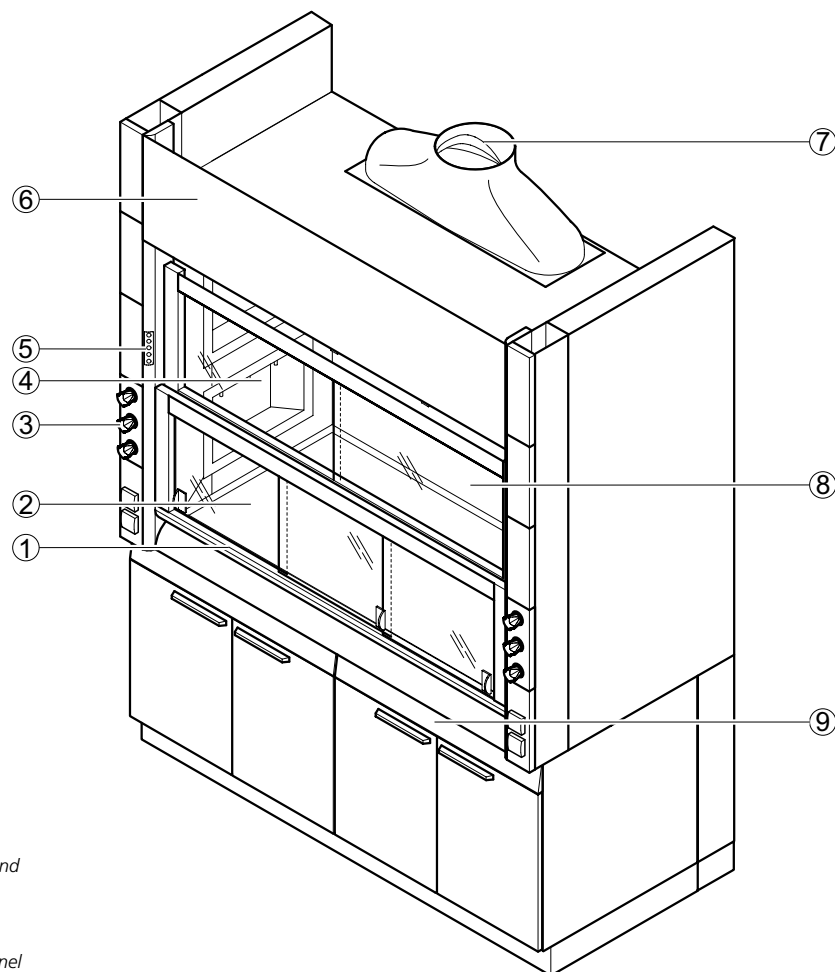

- 1 Two-piece sash with handle and horizontal sashes
- 2 Worktop
- 3 Service panel
- 4 Service module in the side panel of the fume cupboard
- 5 FAZ or AC control panel
- 6 Removable fascia panel
- 7 Extract manifold
- 8 Baffle with scaffold points
- 9 Self-supporting underbench unit

Bench-mounted fume cupboards with side installation Secuflow low ceiling bench-mounted fume cupboard with side installation

Dimensional drawing

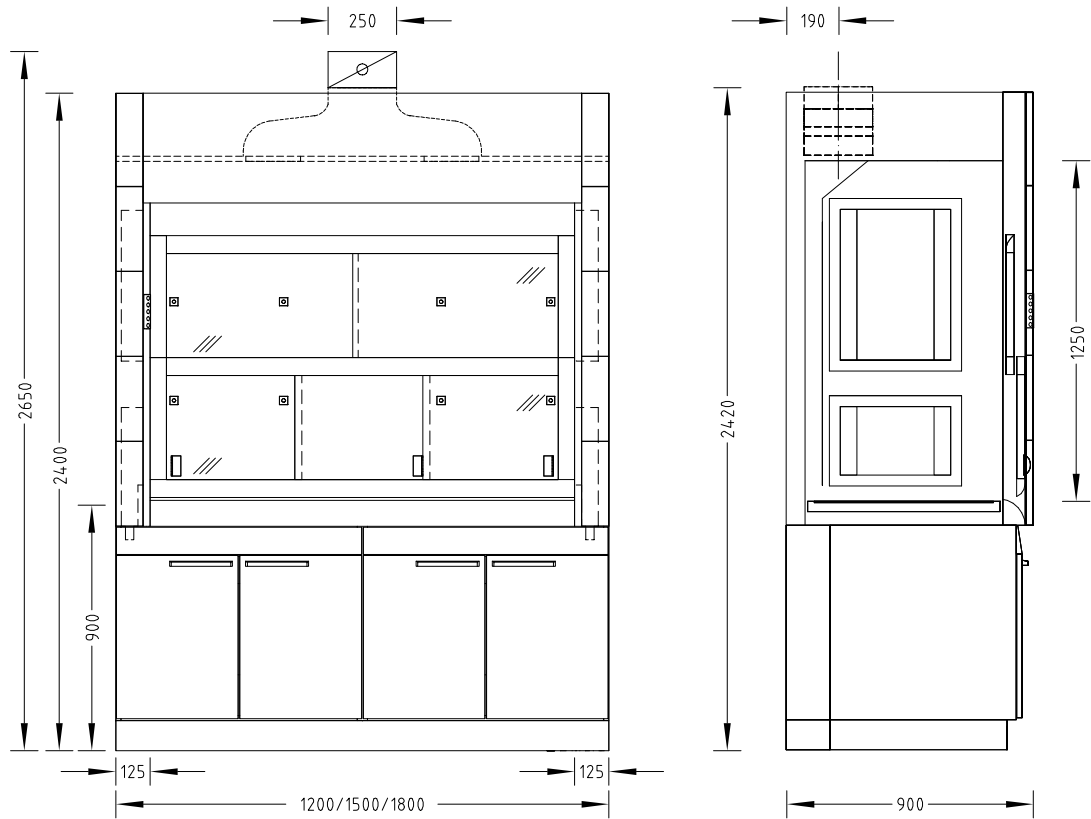

Technical data

Dimensions	1200	1500	1800
Width [mm]	1200	1500	1800
Depth [mm]	900		
Height [mm]	2400		
Clear width, internal workspace [mm]	950	1250	1550
Clear height, internal workspace [mm]	1250		
Working height [mm]	900		

Weight	1200	1500	1800
Without installation [kg]	Approx. 220	Approx. 260	Approx. 300

Bench-mounted fume cupboards with side installation

Secuflow low ceiling bench-mounted fume cupboard with side installation

Design characteristics	1200	1500	1800
Supporting construction	Self-supporting underbench units or H-frame with push-in underbench units		
Two-piece sash	2 horizontal sashes		3 horizontal sashes
Side panel of the fume cupboard	Glass pane on the left and/or right as an option; not if service modules are installed in the side panel of the fume cupboard, not with stoneware internal lining Material lock on the left and/or right as an option; not with stoneware internal lining		
Max. number of devices for scaffold points, ø 12 to 13 mm	6	9	
Service modules	Service modules in the left and/or right side panel of the fume cupboard, depending on requirement		

Electrics	
Electrical supply	External sockets in service panels Internal sockets in service modules
Fuse box	Optional
Sash controller SC	Optional

Sanitary technology	
Sanitary supply	Service modules with take-off valves for vacuum, gases and/or waters and integrated sink (PP) as an option

Ventilation technology	1200	1500	1800
Minimum air exchange rate [m³/h] ¹⁾	330	410	490
Function display	FAZ		
Airflow damper, constant	Airflow-Controller AC		
Airflow damper, variable	Airflow-Controller AC		
Detector of sash position	Only variable with Airflow-Controller AC		
Connection height [mm] for FAZ with extract manifold ø 250 mm	2420		
Connection height [mm] for FAZ with extract manifold ø 315 mm ²⁾	2530		
Connection height [mm] for AC with extract manifold ø 250 mm	2650		
Connection height [mm] for AC with extract manifold ø 315 mm ²⁾	2770		
Underbench exhaust	As an option, depending on requirements and regulations		

¹⁾ All air volume specifications refer to an opening height of the sash window of 500 mm (test opening in acc. with EN 14175) and the maximum tracer gas values recommended by German Standard (BG Chemie). Shown rates correspond to a face velocity of 0.15 m/s. For other design face velocities, please contact your Waldner sales representative.

²⁾ In order to minimise noise and pressure losses, for air volumes >1000 m³/h Waldner recommends using the extract manifold with a connection diameter of 315 mm.

A maximum admission pressure of 600 Pa should not be exceeded in the case of fume cupboards with airflow dampers.

The indicated minimum air exchange rates were determined under specified test conditions in acc. with EN 14175-3. These minimum air exchange rates must be adapted when dimensioning the ventilation system.

If on-site extract air monitoring systems or airflow dampers are used, the required air volumes may be different. The operating limitations must be agreed upon with Waldner.

Material	
Worktop	Stoneware Polypropylene Epoxy Stainless steel
Internal lining	Solid grade laminate Stainless steel Melamine resin facing

Bench-mounted fume cupboards with side installation

Bench-mounted fume cupboard with side installation for work performed while seated

Intended use

- Protective device for the user, tested in acc. with EN 14175
- Extraction of fumes, aerosols and dust from the internal workspace to prevent dangerous amounts of pollutants from escaping into the laboratory
- To prevent the formation of dangerous potentially explosive atmospheres in the internal workspace
- Protection from splashes of hazardous substances
- Protection from flying particles, bodies or parts escaping from the internal workspace
- General fume cupboards constructed in acc. with EN 14175 are normally not suited for use with radioactive substances or microorganisms
- Not suitable for openly breaking down chemicals
- Suitable for work performed while seated
- Service outlets in the service modules of the side panels of the internal workspace
- Control units located vertically on the side service panels

Design

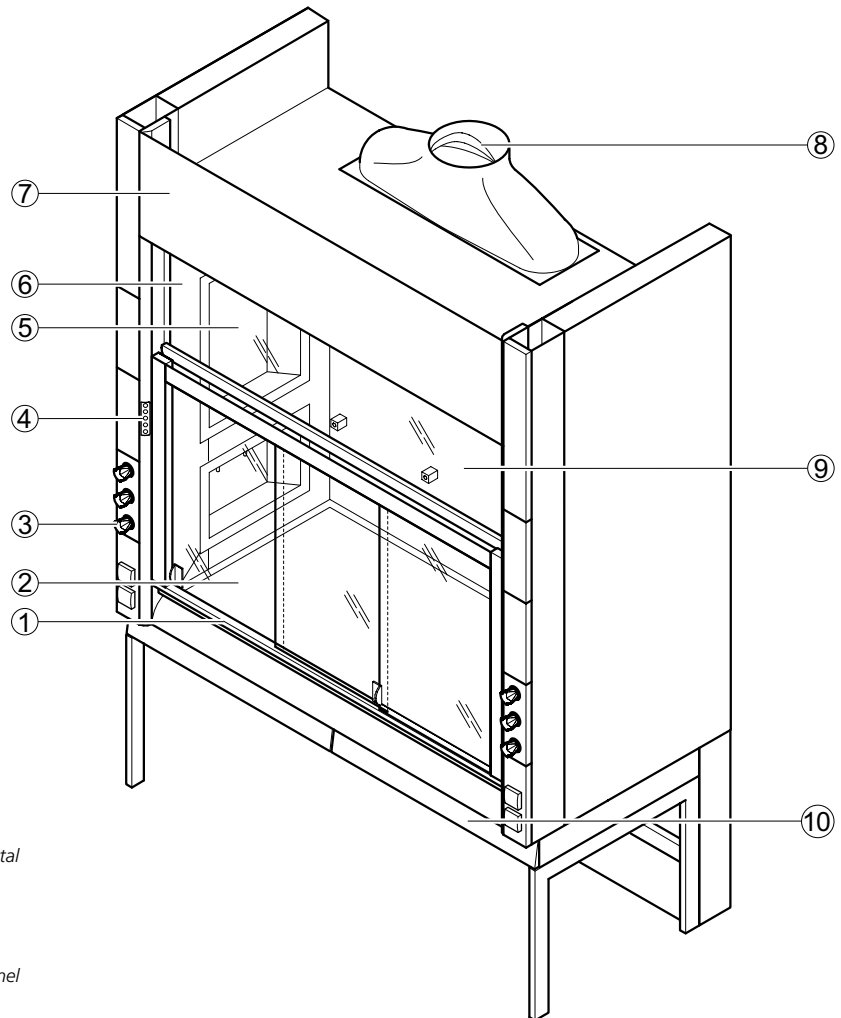

- 1 Sash with handle and horizontal sashes
- 2 Worktop
- 3 Service panel
- 4 FAZ or AC control panel
- 5 Service module in the side panel of the fume cupboard
- 6 Upper sash window
- 7 Removable fascia panel
- 8 Extract manifold
- 9 Baffle with scaffold points
- 10 Support frame with push-in underbench units as an option

Bench-mounted fume cupboards with side installation

Bench-mounted fume cupboard with side installation for work performed while seated

Dimensional drawing

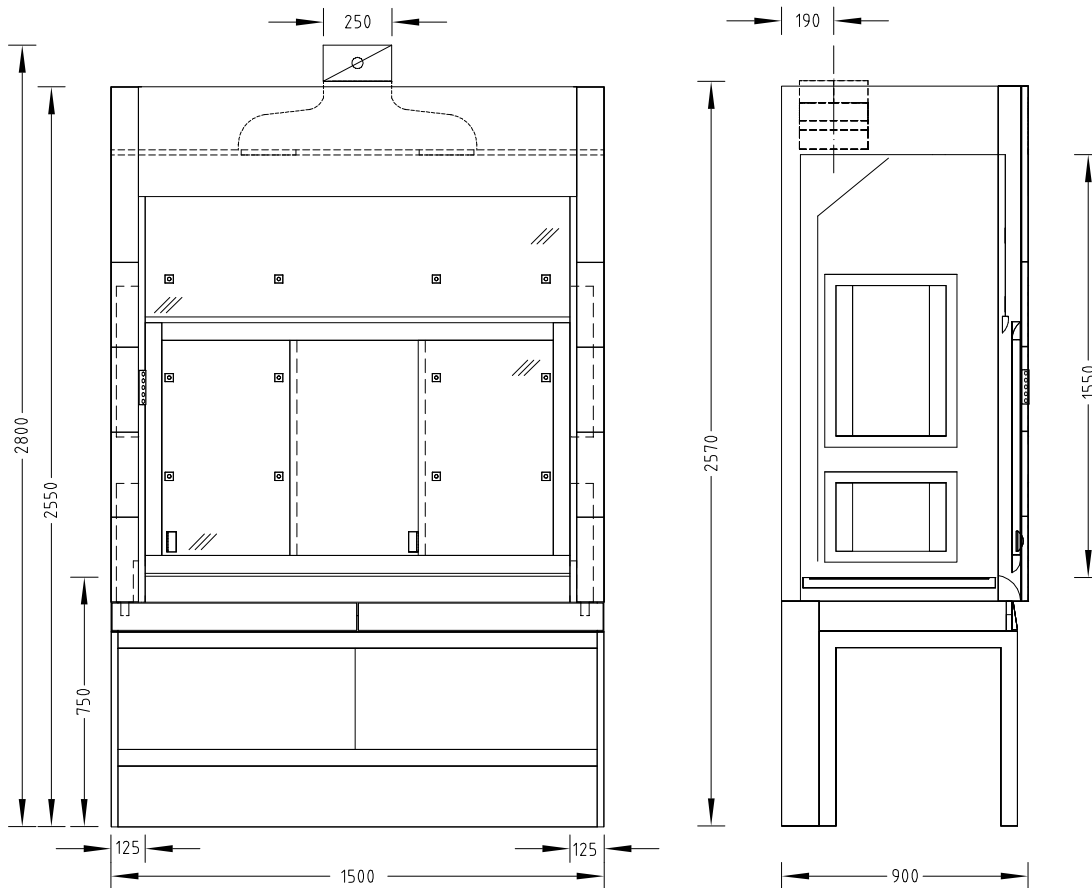

Technical data

Dimensions	
Width [mm]	1500
Depth [mm]	900
Height [mm]	2550
Clear width, internal workspace [mm]	1250
Clear height, internal workspace [mm]	1550
Working height [mm]	750

Weight	
Without installation [kg]	Approx. 390

Bench-mounted fume cupboards with side installation

Bench-mounted fume cupboard with side installation for work performed while seated

Design characteristics	
Supporting construction	H-frame
Sash	2 horizontal sashes
Side panel of the fume cupboard	Glass pane on the left and/or right as an option; not if service modules are installed in the side panel of the fume cupboard Material lock on the left and/or right as an option
Max. number of devices for scaffold points, \varnothing 12 to 13 mm	12
Service modules	Service modules in the left and/or right side panel of the fume cupboard, depending on requirement

Electrics	
Electrical supply	External sockets in service panels Internal sockets in service modules
Fuse box	Optional
Sash controller SC	Optional

Sanitary technology	
Sanitary supply	Service modules with take-off valves for vacuum, gases and/or waters and integrated sink (PP) as an option

Ventilation technology	
Minimum air exchange rate [m ³ /h] ¹⁾	530
Function display	FAZ
Airflow damper, constant	Airflow-Controller AC
Airflow damper, variable	Airflow-Controller AC
Detector of sash position	Only variable with Airflow-Controller AC
Connection height [mm] for FAZ with extract manifold \varnothing 250 mm	2570
Connection height [mm] for FAZ with extract manifold \varnothing 315 mm ²⁾	2730
Connection height [mm] for AC with extract manifold \varnothing 250 mm	2800
Connection height [mm] for AC with extract manifold \varnothing 315 mm ²⁾	2920
Underbench exhaust	As an option, depending on requirements and regulations

¹⁾ All air volume specifications refer to an opening height of the sash window of 500 mm (test opening in acc. with EN 14175) and the maximum tracer gas values recommended by German Standard (BG Chemie). Shown rates correspond to a face velocity of 0.24 m/s. For other design face velocities, please contact your Waldner sales representative.

²⁾ In order to minimise noise and pressure losses, for air volumes >1000 m³/h Waldner recommends using the extract manifold with a connection diameter of 315 mm.

A maximum admission pressure of 600 Pa should not be exceeded in the case of fume cupboards with airflow dampers. The indicated minimum air exchange rates were determined under specified test conditions in acc. with EN 14175-3. These minimum air exchange rates must be adapted when dimensioning the ventilation system.

If on-site extract air monitoring systems or airflow dampers are used, the required air volumes may be different. The operating limitations must be agreed upon with Waldner.

Material	
Worktop	Stoneware Polypropylene Epoxy Stainless steel
Internal lining	Solid grade laminate Melamine resin facing

Bench-mounted fume cupboards with side installation

Secuflow bench-mounted fume cupboard with side installation for work performed while seated

Intended use

- Protective device for the user, tested in acc. with EN 14175
- Extraction of fumes, aerosols and dust from the internal workspace to prevent dangerous amounts of pollutants from escaping into the laboratory
- To prevent the formation of dangerous potentially explosive atmospheres in the internal workspace
- Protection from splashes of hazardous substances
- Protection from flying particles, bodies or parts escaping from the internal workspace
- General fume cupboards constructed in acc. with EN 14175 are normally not suited for use with radioactive substances or microorganisms
- Not suitable for openly breaking down chemicals
- Suitable for work performed while seated
- Active supportive flow technology (Secuflow technology) reduces the energy consumption while regulations and standards are observed
- Service outlets in the service modules of the side panels of the internal workspace
- Control units located vertically on the side service panels

Design

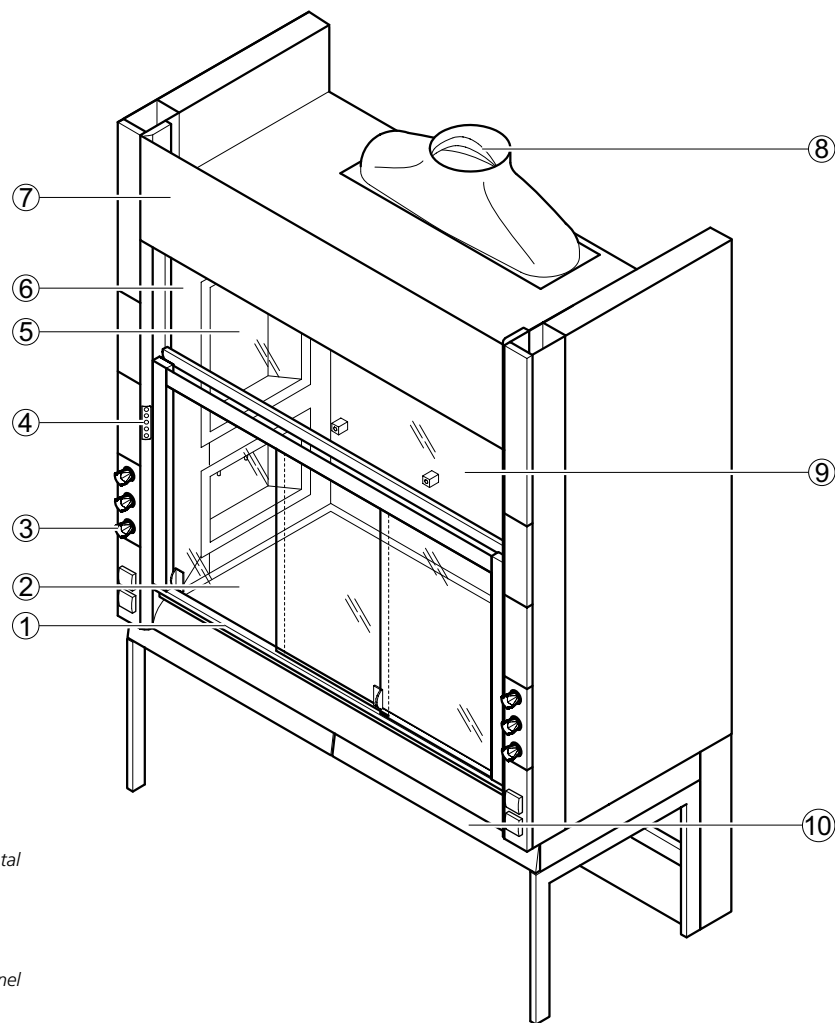

- 1 Sash with handle and horizontal sashes
- 2 Worktop
- 3 Service panel
- 4 FAZ or AC control panel
- 5 Service module in the side panel of the fume cupboard
- 6 Upper sash window
- 7 Removable fascia panel
- 8 Extract manifold
- 9 Baffle with scaffold points
- 10 Support frame with push-in underbench units as an option

Bench-mounted fume cupboards with side installation

Secuflow bench-mounted fume cupboard with side installation for work performed while seated

Dimensional drawing

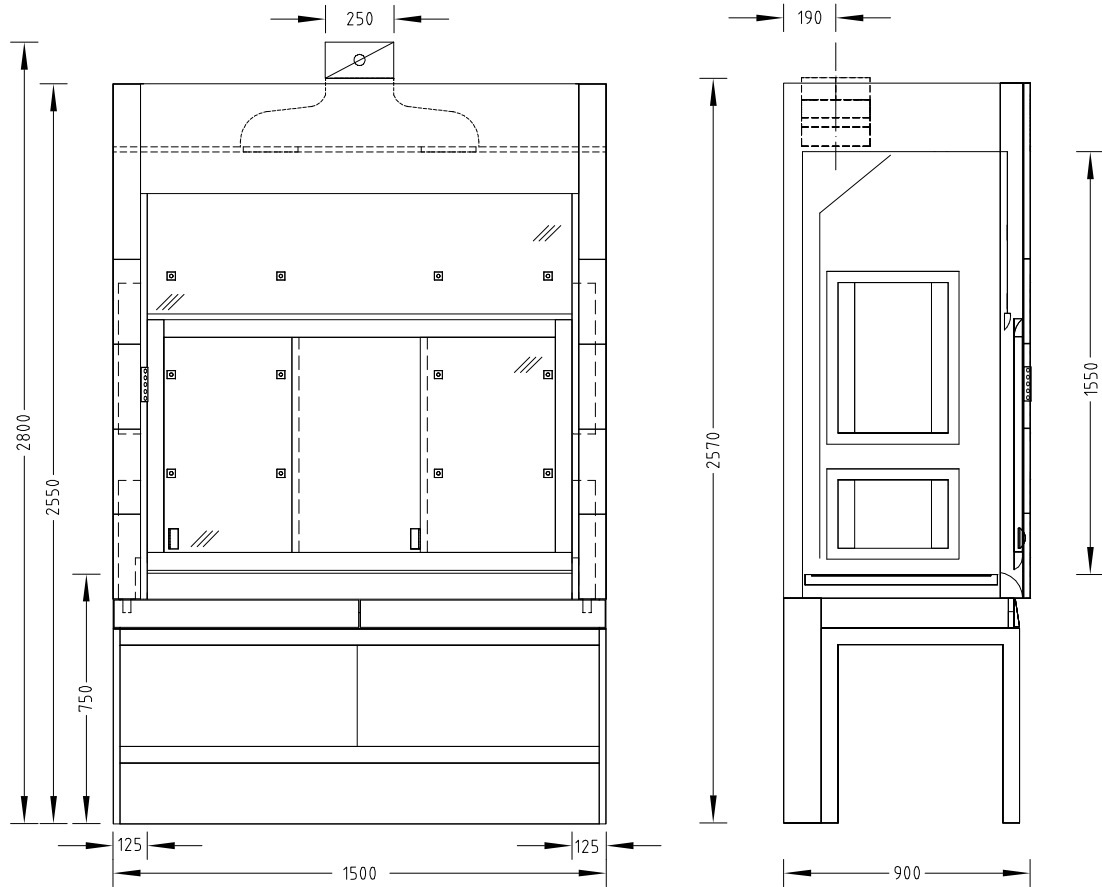

Technical data

Dimensions	
Width [mm]	1500
Depth [mm]	900
Height [mm]	2550
Clear width, internal workspace [mm]	1250
Clear height, internal workspace [mm]	1550
Working height [mm]	750

Weight	
Without installation [kg]	Approx. 390

Bench-mounted fume cupboards with side installation

Secuflow bench-mounted fume cupboard with side installation for work performed while seated

Design characteristics	
Supporting construction	H-frame
Sash	2 horizontal sashes
Side panel of the fume cupboard	Glass pane on the left and/or right as an option; not if service modules are installed in the side panel of the fume cupboard Material lock on the left and/or right as an option
Max. number of devices for scaffold points, ø 12 to 13 mm	12
Service modules	Service modules in the left and/or right side panel of the fume cupboard, depending on requirement

Electrics	
Electrical supply	External sockets in service panels Internal sockets in service modules
Fuse box	Optional
Sash controller SC	Optional

Sanitary technology	
Sanitary supply	Service modules with take-off valves for vacuum, gases and/or waters and integrated sink (PP) as an option

Ventilation technology	
Minimum air exchange rate [m ³ /h] ¹⁾	410
Function display	FAZ
Airflow damper, constant	Airflow-Controller AC
Airflow damper, variable	Airflow-Controller AC
Detector of sash position	Only variable with Airflow-Controller AC
Connection height [mm] for FAZ with extract manifold ø 250 mm	2570
Connection height [mm] for FAZ with extract manifold ø 315 mm ²⁾	2730
Connection height [mm] for AC with extract manifold ø 250 mm	2800
Connection height [mm] for AC with extract manifold ø 315 mm ²⁾	2920
Underbench exhaust	As an option, depending on requirements and regulations

¹⁾ All air volume specifications refer to an opening height of the sash window of 500 mm (test opening in acc. with EN 14175) and the maximum tracer gas values recommended by German Standard (BG Chemie). Shown rates correspond to a face velocity of 0.15 m/s. For other design face velocities, please contact your Waldner sales representative.

²⁾ In order to minimise noise and pressure losses, for air volumes >1000 m³/h Waldner recommends using the extract manifold with a connection diameter of 315 mm.

A maximum admission pressure of 600 Pa should not be exceeded in the case of fume cupboards with airflow dampers.

The indicated minimum air exchange rates were determined under specified test conditions in acc. with EN 14175-3. These minimum air exchange rates must be adapted when dimensioning the ventilation system.

If on-site extract air monitoring systems or airflow dampers are used, the required air volumes may be different. The operating limitations must be agreed upon with Waldner.

Material/surface	
Worktop	Stoneware Polypropylene Epoxy Stainless steel
Internal lining	Solid grade laminate Melamine resin facing